



Manual INTD0521

4.3"/5" TFT-LCD COLOR
FLOOR INDICATOR w/ Floor Announcement



- Page 2 Description - Specifications
- Page 3 Typical wiring diagram
- Page 4 DIP switch functionality/ECO input

Please read all the instruction carefully in order to exploit all the advantages of this device.

4.3"/5" TFT-LCD COLOR
FLOOR INDICATOR

INTD0521



Description:

The INTD0521 device is a color TFT-LCD floor indicator with Floor Announcement functionality that comes with on board micro SD card graphics and audio storage.

Also the device support BCD/OWPF (One wire per floor) control panel inputs formats selected via on board DIP switch.

Additionally user can select various graphics themes from our supported PC software for customizing arrow types, background themes etc..

Specifications

Power supply	12 to 24 V DC/AC
Current input consumption	0.25A max (12V DC input and 100% backlight illumination)
Display resolution	480x272pixels
Color depth	16bit
Color pixel format	565 (5bit Red, 6bit Green, 5bit Blue)
Input panel formats support	<ul style="list-style-type: none"> Decimal (One wire per floor) BCD Additional input format support ⁽¹⁾
Supported micro SD card	Capacity: 1GB, 2GB, 4GB, 8GB, 16GB, 32GB Class: Class 2, Class 4, Class 6
Supported micro SD format:	FAT16 , FAT32
Other	<ul style="list-style-type: none"> Overload/Functionality on board buzzer tone indication. Starting floor selection via on board DIP switch (3 floor range). Input panel format selection via DIP switch (BCD/Binary). Auto power save mode for backlight illumination.

(1) Custom made possibility

Note: Remove power supply/Connections before inserting micro SD card.

During "HOT" remove of the micro SD card, please repower the device before using.



Typical wiring diagram:

Typical connection to control panel with BCD output format and extra input connection, to ECO/Arrows/Service/Overload, as shown in fig.1.
 (Device as seen from back side-PCB back view).

Figure 1. DIP switch Micro SD (Graphics-Audio)

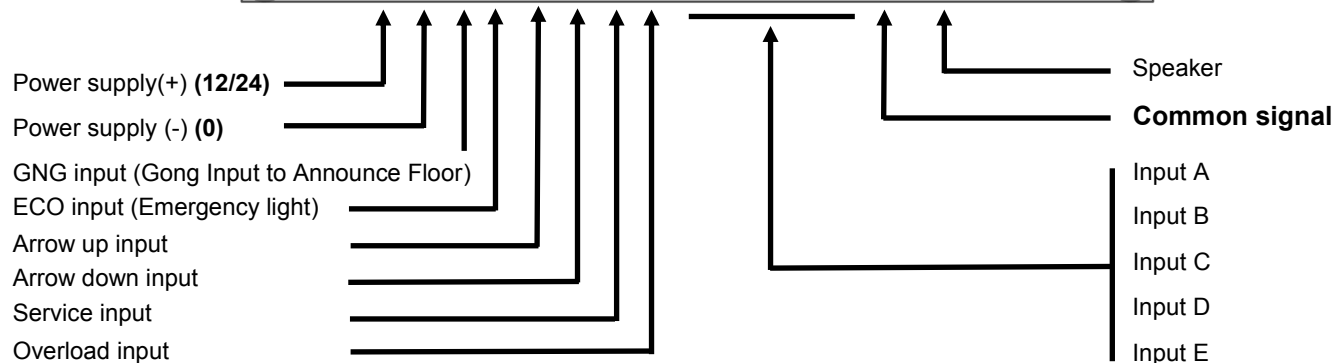
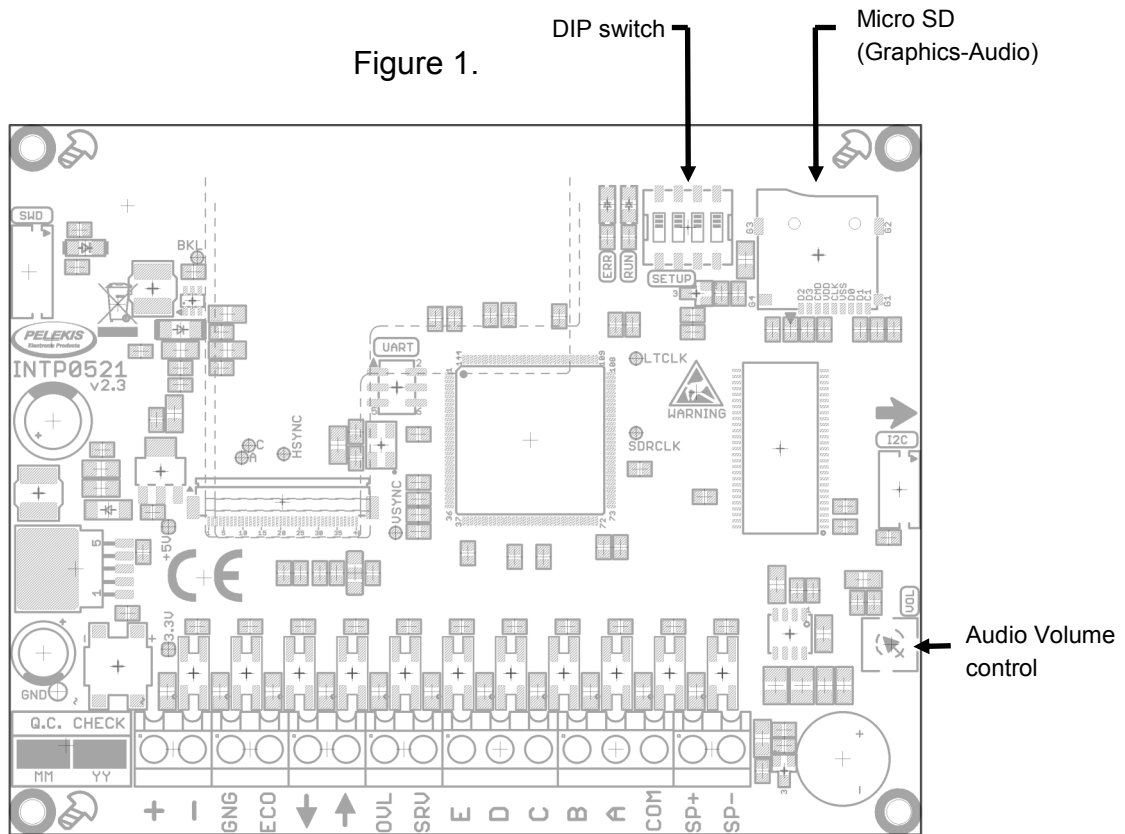

DIP switch functionality:

The DIP switch settings located on back side of floor indicator PCB are shown on the tables below.

Function: <i>Starting floor selection</i>		
1	3	Starting floor
OFF	OFF	-3
OFF	ON	-2
ON	OFF	-1
ON	ON	0

Function: <i>Input format</i>	
4	Input format
OFF	ONE WIRE PER FLOOR
ON	BCD

DIP switch

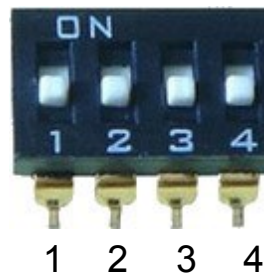

ON

OFF

ECO input:

If ECO input is OFF (not connected), the device enters in emergency light mode, thus the screen shows white backlight with full brightness.

If ECO input is ON (connected), the device enters in normal mode (as floor indicator), **see. figure 1.**

GNG input:

If GNG input is OFF (not connected), the device is not able to announce the floor during any Floor-input change.

If GNG input is ON (connected), the device will announce the upcoming Floor while on any change state of ABCDE inputs